

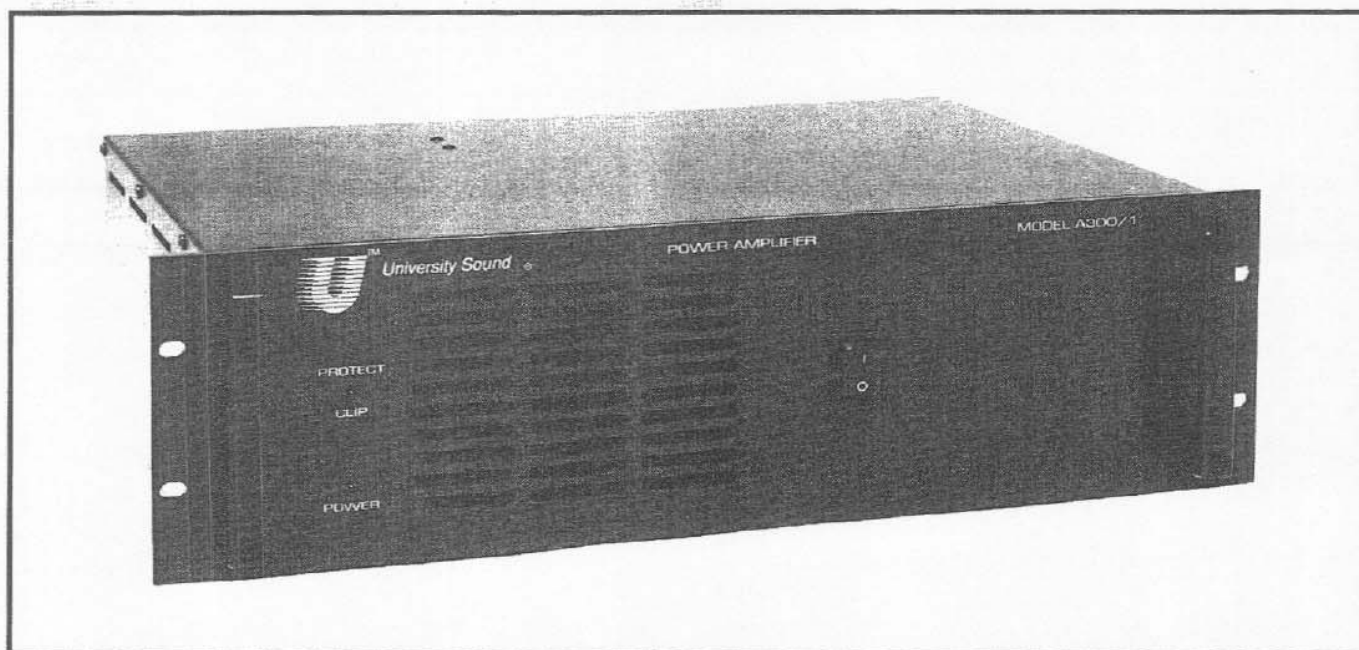

A300/1

300 Watt Single-Channel Power Amplifier



Product Data

- **300 Watts continuous average output power on a single channel**
- **Low noise design for reduced hum and RF susceptibility**
- **Four input connector types: screw-terminal, male XLR, female XLR, and RCA phono jack.**
- **Balanced bridging input**
- **Pre-fader and post-fader auxiliary outputs**
- **4 Ohm, 8 Ohm, 25V, and 70.7V speaker outputs**
- **Rack-mountable 3-space enclosure**

Summary Specifications:

Power Output	300 Watts continuous
Frequency Response	20 Hz - 20 kHz, +0 -1 dB
Signal-to-Noise Ratio	> 100 dB
Distortion	< 0.1%THD
Input Sensitivity/Impedance	
Balanced Line In	0 dBu / 15 k Ω
Unbalanced Line In	0 dBu / 47 k Ω
Power Requirements	120/220/240VAC, 50/60Hz
Dimensions	
Height	5.25" (13.3 cm)
Length	19.0" (48.2 cm)
Width	13.0" (33.0 cm)
Net Weight	42 lbs. (19 kg)
Shipping Weight	51 lbs. (23 kg)

Description

The University Sound A300/1 power amplifier is a high quality low cost monaural amplifier for general purpose applications. It produces 300 watts of continuous average output power. Included are many built-in features that far exceed what is normally found in amplifiers of this type. For example, the amplifier includes a 15 k Ω electronically balanced bridging input, and choice of four input connector types: a three-screw terminal removable plug, female XLR, male XLR, and phono connector. The male XLR is also usable as a convenient patch output point for routing the input signal to another amplifier.

Two auxiliary unbalanced outputs are also provided. One is before (pre-fader), and the other after (post-fader), the MASTER output level control. These outputs greatly simplify many complex

system designs. In addition to a direct output capable of driving 4 Ohm or 8 Ohm loads, the A300/1 also provides an 8 Ohm autoformer output and 25 Volt and 70.7 Volt outputs for distributed speaker systems.

The amplifier is fully protected from short circuited loads, overheating, and excessive load reactance, and the loads from turn-on/turn-off transients, subsonic signals, and DC offsets. When a problem is detected, the amplifier automatically shuts down and illuminates the front panel PROTECT indicator. In addition, a front panel clipping indicator warns of excessive output levels. The MASTER level control is rear mounted for extra protection against "accidental" changes made by non-qualified personnel.

Block Diagram

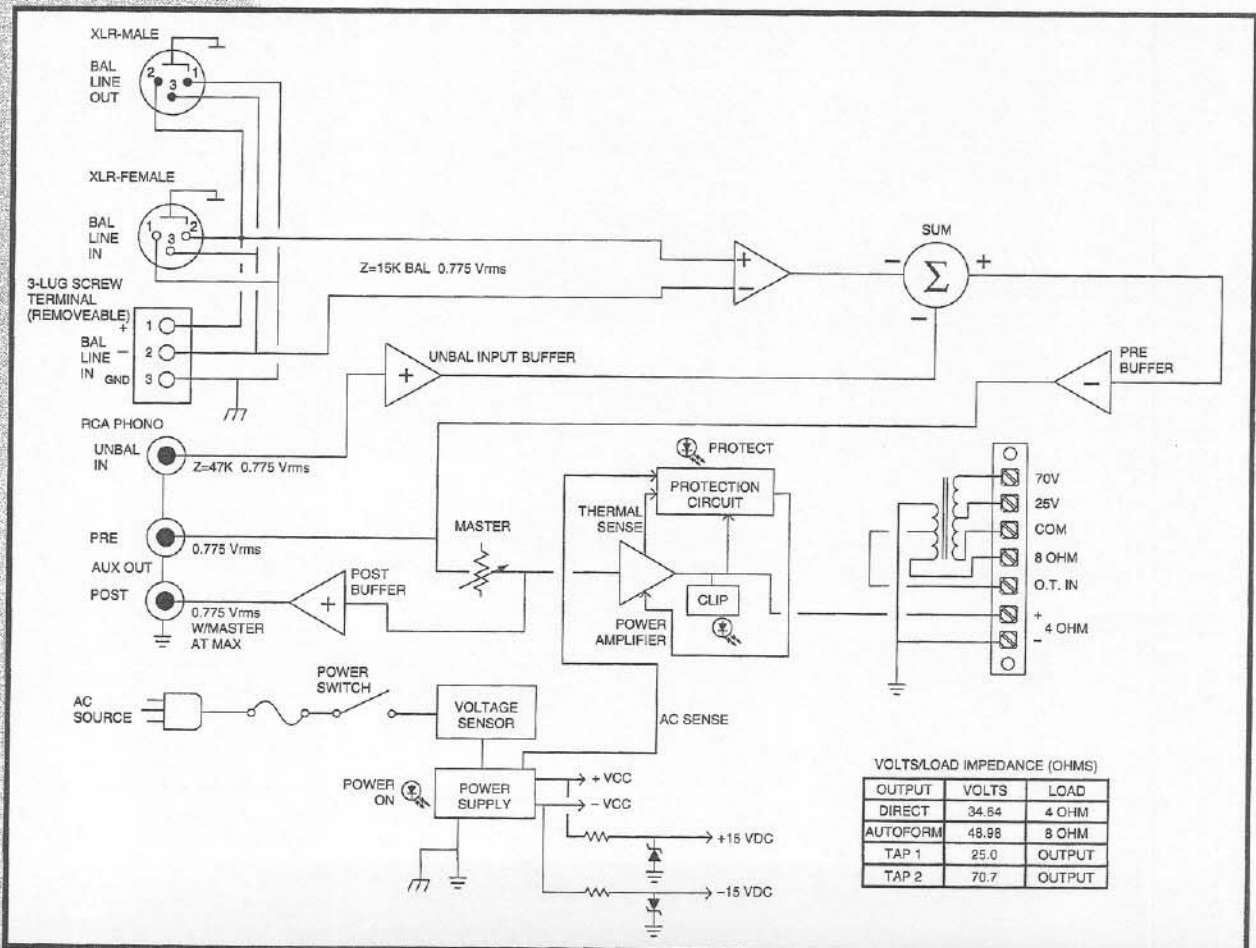

Full Specifications

Continuous average power (direct or transformer output)	300 Watts	Output level/Load impedance (ref. 1 kHz, 0 dBu=0.775 Vrms applied to balanced line input, ± 1 dB)	Line output (balanced) 0 dBu / 15 kHz PRE Auxiliary out (unbal) 0 dBu / 600Ω POST Auxiliary out (bal) 0 dBu / 600Ω
Maximum midband output power (Ref. 1 kHz, 1% THD)	400 Watts	Power Outputs	Direct, unbalanced 34.64 Vrms / 4Ω Direct, unbalanced 34.64 Vrms / 8Ω Autotransformer, unbal 48.98 Vrms / 8Ω Transformer, balanced 25 Vrms / 2.08Ω Transformer, balanced 70.7 Vrms / 16.6Ω
Transformer output (any output tap)	300 Watts	Damping factor (at 1kHz, direct output)	>150
Power Bandwidth (ref. 1 kHz @ rated output power)	Direct Output 20 Hz - 20 kHz, +0/-1 dB	Output regulation (ref. 1 kHz, no load to full load)	Direct output <0.05 dB Transformer output <1.2 dB
Transformer Output (any output tap)	50 Hz - 15 kHz, +0/-1.5 dB	Signal-to-Noise ratio (A-weighted, MASTER at full clockwise position)	> 100 dB
Frequency Response (ref. 1 kHz at 1 Watt output power)	Direct output 20 Hz - 15 kHz, ± 1 dB 10 Hz - 30 kHz, ± 1.5 dB	Power Requirements	120, 220, or 240 VAC, 50/60 Hz
Transformer output (any output tap)	20 Hz - 15 kHz, ±1.5 dB 10 Hz - 30 kHz, ± 3 dB	Power consumption	Max. output power 710 Watts 1/3 max. output power 450 Watts
Total Harmonic Distortion (THD) (ref. 1 kHz at rated output power, 30 kHz low pass filter)	Direct output 20 Hz <0.1% 1 kHz <0.05% 20 kHz <0.05%	Minimum operating supply voltage	90 VAC (at reduced output power and performance)
Transformer output (any output tap)	50 Hz <0.1% 1 kHz <0.1% 15 kHz <0.05%	Operating temperature	140°F (60°C) maximum
Intermodulation Distortion (SMPTE, 4:1, at rated output power, direct output)	<0.05% (typ. <0.01%)	Dimensions	Height 5.25" (13.3 cm) Width 19.0" (48.2 cm) Depth 13.0" (33 cm)
Input Sensitivity/Input Impedance (ref. 1kHz, 0 dBu=0.775 Vrms)	Balanced line input 0 dBu / 15 kΩ Unbalanced line input 0 dBu / 47 kΩ	Net Weight	42 lbs. (19 kg)
Maximum input level (ref. 1 kHz signal, MASTER off)	Balanced input +18 dBu (6.2 Vrms) Unbalanced input +18 dBu (6.2 Vrms)	Shipping Weight	51 lbs. (23 kg)
		Color	Black

Rear Panel View

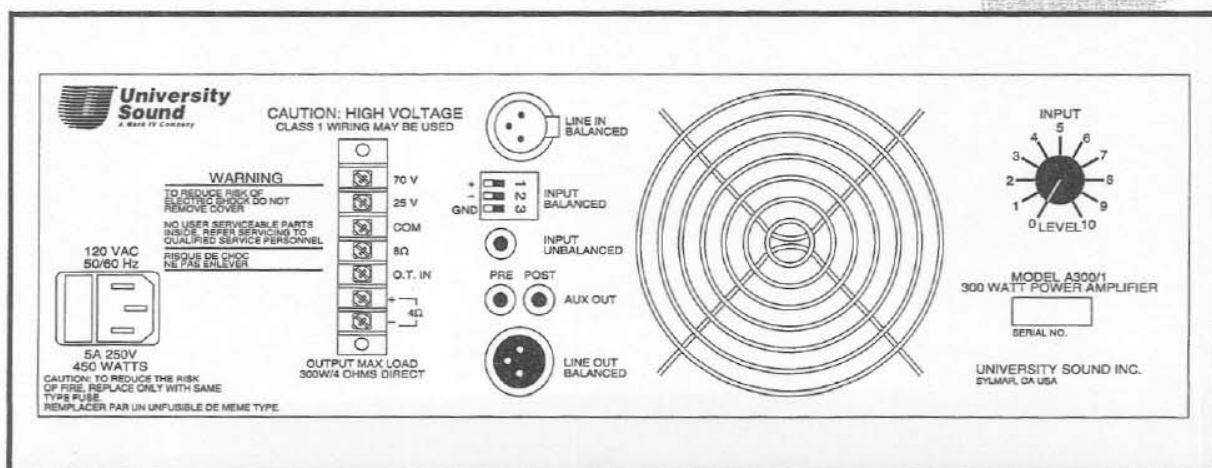

Architect's and Engineer's Specifications

The power amplifier shall be a monaural amplifier of solid state design employing true complementary symmetry output circuitry and capable of operating from a 120, 220, or 240 VAC, 50/60 Hz power source. The amplifier shall provide a plurality of balanced transformer output taps as well as an unbalanced direct output, and a 15K Ohm electronically balanced bridging input. The amplifier shall contain sensing circuitry to provide protection for the output transistors against over temperature, excessive output voltage, radio frequency interference, excessive output current, and excessive output phase shift. The load shall be similarly protected against subsonic signals, startup/shutdown transients, low AC line voltage, and DC offsets.

There shall be a rear panel mounted input level control. Input connectors shall include a 3-lug screw terminal connector and a 3-pin XLR female connector for balanced inputs, and a phono connector for unbalanced inputs. Output connectors shall include a 3-pin XLR male connector, two phono connectors as auxiliary unbalanced outputs, and a 7-terminal barrier strip connector.

Front panel illuminated indicators shall include a power on/off indicator, a signal clipping indicator, and a protection circuit activation indicator. The front panel control shall be the power on/off switch.

The amplifier shall include a balanced bridging input with a nominal input impedance of 15K Ohms. A power output isolation transformer shall provide balanced outputs of 25 Volts (2.08 Ω load) and 70.7 Volts (16.6 Ω load). A direct output of 4 Ω (34.64V) and also an unbalanced auto-former output of 8 Ω shall be provided.

The power amplifier shall be enclosed in a sturdy steel cabinet measuring 5.25" x 19" x 13". The cabinet shall be rack mountable in a standard 19" equipment rack and occupy three rack spaces.

The University Sound Model A300/1 has been specified.

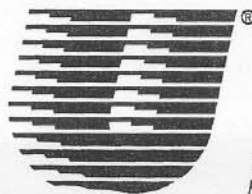

**University
Sound** a MARK IV
company

P.O. Box 24031
Oklahoma City, OK 73124-4031
Phone (405) 324-5311
Fax (405) 324-8981